

# Linear Acoustic® LA-5291

## Audio Encoding, Transcoding, and Decoding for Live Dolby Atmos® Workflows



## OVERVIEW

The Linear Acoustic LA-5291 Professional Audio Encoder allows you to create an exciting and immersive Dolby Atmos® experience via a Dolby Digital Plus JOC bitstream for production workflows, platforms, and delivery streams that do not require Dolby AC-4. The LA-5291 offers decoding, encoding, and transcoding to and from PCM and select Dolby® coded formats for up to 16 audio channels.

## FEATURES

- Decoding from Dolby ED2 to PCM
- Transcoding from Dolby ED2 and Dolby E to Dolby Digital Plus and Dolby Digital Plus JOC
- Encoding PCM to Dolby Digital Plus, Dolby Digital Plus JOC, and Dolby ED2
- 3Gb/s HD/SD-SDI and AES-3 I/O
- AES67 I/O in support of SMPTE ST 2110-30 and -31 workflows
- Optional Quad-Link 3Gb/s SDI I/O for supporting 4K video workflows, or optional MADI I/O (mutually exclusive options)
- Dual internal redundant auto-ranging power supplies
- Browser-based remote control

## IN DEPTH

### Supporting Today's Dolby Atmos Workflows

While emerging standards such as ATSC 3.0 continue to advance and provide improved immersive audio for OTA broadcast, the amount of cinematic and live content produced in Dolby Atmos continues to grow as well reaching consumers via Blu-ray Disc, satellite, cable, and streaming services. The workflow required to create, transport, and deliver that content to viewers at home can be complex, requiring the ability to work with PCM, Dolby ED2, Dolby E, Dolby Digital Plus, and Dolby Digital Plus JOC formats - tasks for which the LA-5291 was purpose-built.

### Equally at Home for Contribution and Distribution

The LA-5291 integrates well into remote and OB trucks for encoding multi-channel PCM audio into Dolby Digital Plus, Dolby Digital Plus JOC, or Dolby ED2 for distribution. Further downstream, it can transcode Dolby ED2 and Dolby E directly to Dolby Digital Plus and Dolby Digital Plus JOC, and can encode PCM to Dolby Digital Plus and Dolby Digital Plus JOC for final distribution.

## LA-5291 | Audio Encoding, Transcoding, and Decoding for Live Dolby Atmos® Workflows

## End-to-End Workflow

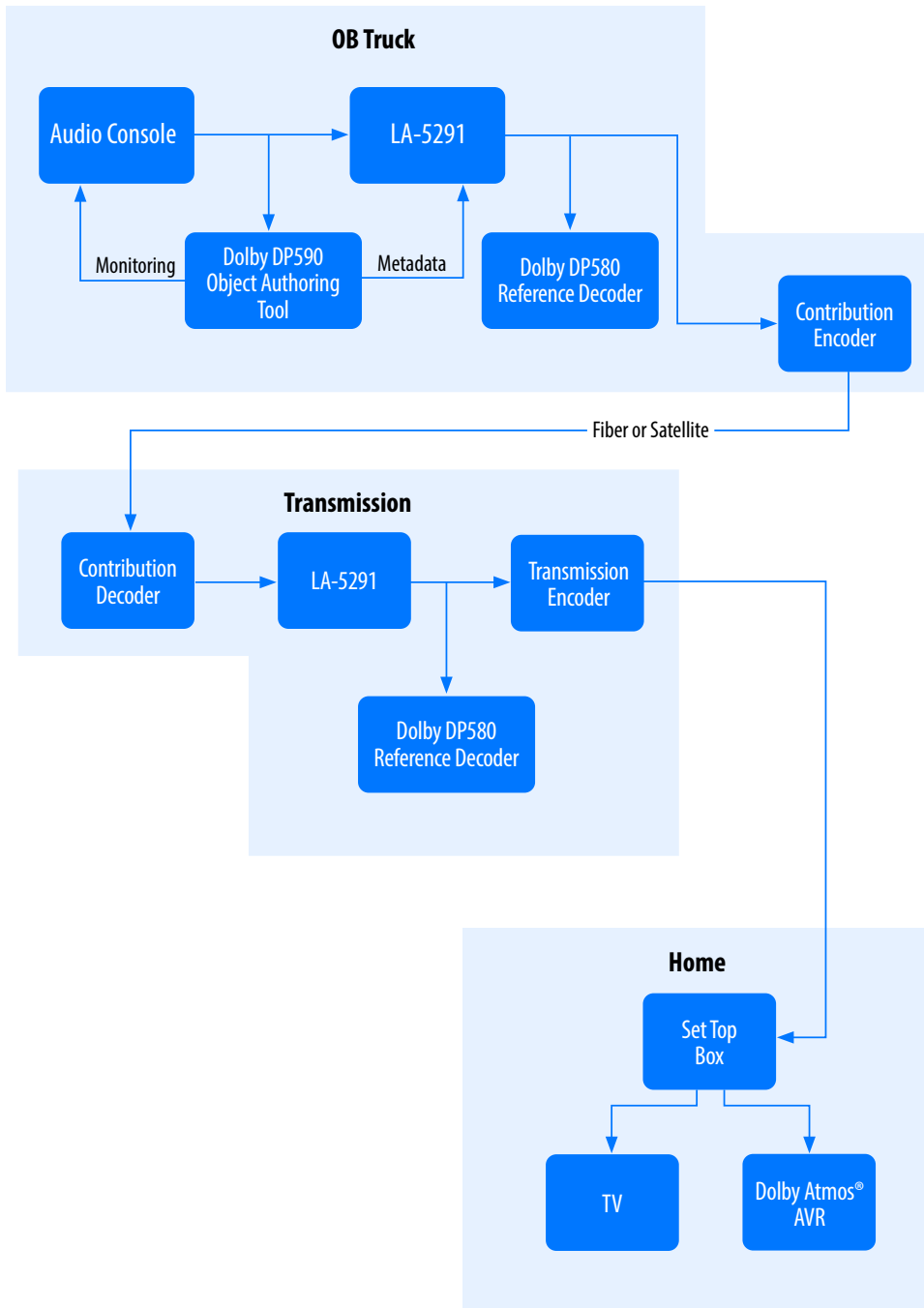

LA-5291 | Audio Encoding, Transcoding, and Decoding for Live Dolby Atmos® Workflows

OB Truck/Production Workflow

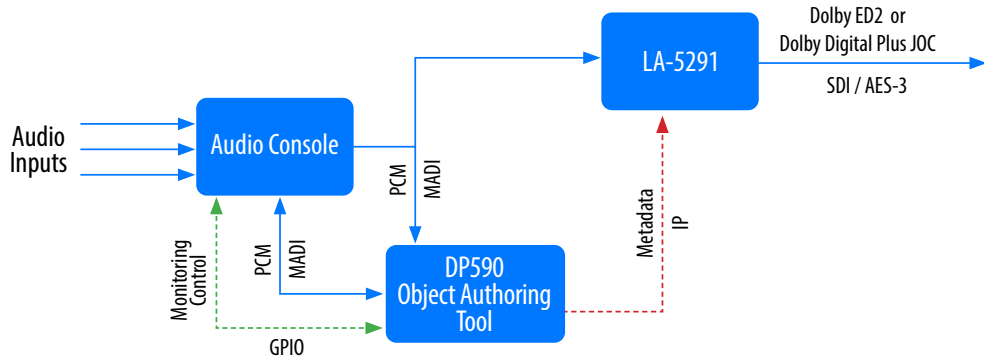

Broadcast Center Decode / Insert / Encode

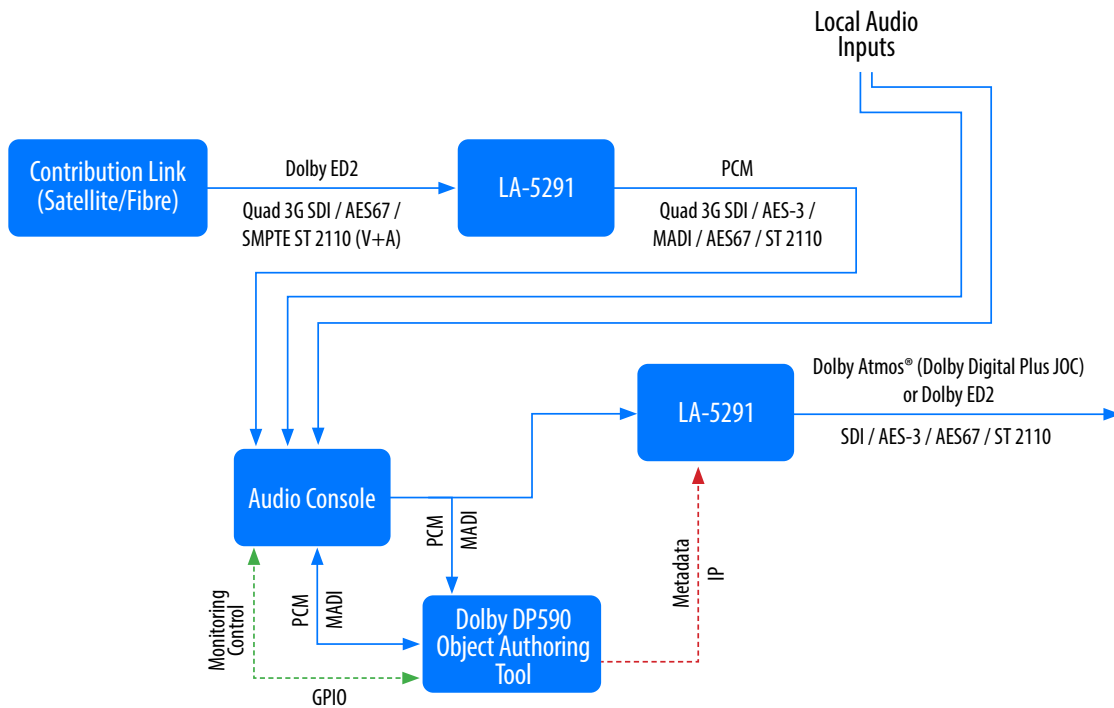

## SPECIFICATIONS

### Decoding

- Decoding from Dolby ED2 to PCM

### Transcoding

- Transcodes Dolby ED2 and Dolby E to Dolby Digital Plus and Dolby Digital Plus JOC

### Encoding

- Encodes PCM to Dolby Digital Plus, Dolby Atmos (via Dolby Digital Plus JOC), and Dolby ED2

### 3G HD/SD-SDI I/O

- Two independent auto-sensing 3Gb/s HD/SD-SDI inputs (SMPTE ST 425-1, 292M, and 259M), up to 1080i/60/59.94/50Hz
- Optional Quad-Link 3Gb/s SDI for 4K workflows (mutually exclusive with MADI option)

### AES-3 I/O

- 5 stereo pairs via 75 Ohm BNC unbalanced female connectors, internally terminated; signal levels per SMPTE 276M/AES-3ID-2001

### AES67 I/O

- 16 channels of bi-directional AES67 I/O in support of SMPTE ST 2110-30 and -31 workflows

### MADI I/O

- Optional MADI I/O supports up to 16 channels for processing
- Passthrough and shuffling for up to 64 channels
- I/O via coax or optical SFP socket (SFP sold separately)
- MADI option mutually exclusive with Quad-Link SDI option

### Reference

- 48kHz reference via SDI, PTP, AES-3, internal clock (standalone use only), or MADI (when MADI option is installed)
- Vref

## Sample Rate/Resolution/Frequency Response

- 48kHz, 24-bit, 20Hz – 20kHz

## Ethernet

- Two Gigabit RJ-45 connections – one for AES67, one for networked remote control

## Parallel GPI/O Control Port

- 15-pin female D connector, 0-5V TTL levels, 5 GPI/O inputs, 5 GPI/O outputs

## Power

- Dual internal redundant auto-ranging power supplies
- 95-240 VAC, 50/60 Hz, 100W maximum total

## Dimensions and Weight

- 19" W x 15.5" D x 1.75" H (approximately 48.2 x 39.4 x4.5 cm )
- Net weight: Approximately 9.0 lbs (4.08 kg)
- Approximate shipping weight 16 lbs (7.26 kg)

## Regulatory

- North America – FCC and CE tested and compliant with UL-approved power supplies
- Europe – Complies with European Union Directive 2002/95/EC on the restriction of use of certain hazardous substances in electrical and electronic equipment (RoHS), as amended by Commission Decisions 2005/618/EC, 2005/717/EC, 2005/747/EC (RoHS directive), and WEEE

## Warranty

- Standard Telos Alliance 2-year limited parts and labor